



Ultrasonic GSM 2G Installation Guide

Thank you for purchasing the Tekelek Ultrasonic GSM 2G sensor which uses ultrasonic technology to measure the liquid level of your tank and then communicates this data to a remote server.



STEP 2: Activation

- To activate the sensor, hold the supplied magnet to the hot spot, a beep will be heard to indicate correct placement of magnet.



- Keep the magnet held to the hot spot until a second beep is heard, remove magnet from hot spot once this has been achieved.
- A series of beeps will now be heard. This indicates the GSM/GPRS is registering onto the GSM network.
- Upon successful registration to the GSM network the sensor will attempt to initiate a GPRS connection to the server. This is indicated by higher pitched beeping.
- The successful activation of the sensor is indicated by two successive short beeps two seconds apart. This will wake the sensor from dormant mode and activate it to make a join-request to the server.

Beep Patterns:

Beep Pattern	Definition
Low beep once per second	Network Registration
High beep once per second	GPRS Registration
Low beep once every 4 seconds	Network / TCP Listen
Low beep once every 2 seconds	Re-establish Network / TCP
High / Low combination beep	Incoming Data
Low / High combination beep	Outgoing Data
Low double-beep every 4 seconds	Network Listen (Data Received & Unit Active)
Low double-beep every 2 seconds	Re-establish Network
High double-beep every 4 seconds	TCP Listen (Data Received & Unit Active)
High double-beep every 2 seconds	Re-establish TCP

STEP 2: Installation

The Ultrasonic GSM 2G sensor works in conjunction with a remote server and before installation must first be registered to this. Access to the backend server is required to verify that the unit has correctly joined the network.

The following outlines the sensor mounting options.

- The sensor must sit in a vertical position on top of the tank and be fitted such that the sensor has a clear path to the tank contents. Position it so that there are no internal obstructions that may interfere with the ultrasonic signal.

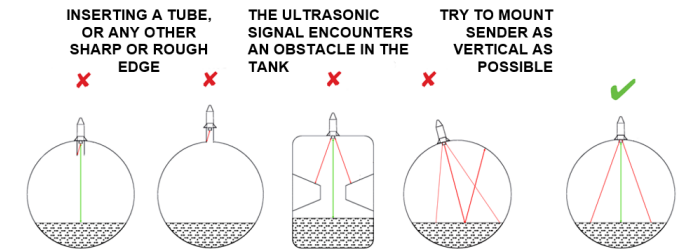

- If obstacles cannot be avoided, then a waveguide may be required. Please refer to [Appendix 2](#) for further details.
- Locate a suitably positioned threaded opening on the top of the tank to hold the sensor.
 - The sensor will fit directly into threaded 1 1/4", 1 1/2" or 2" BSP (British Standard Pipe) existing tank connections.
 - Ensure that the gasket is placed, and that the sensor is screwed correctly into the tank.
- For tanks that do not contain a suitably positioned threaded opening on the top of the tank to hold the sensor, please refer to [Appendix 1](#).



Appendix 1: Drilling Procedure

- Choose a flat spot on the top of the tank.
- Use a 45.5mm tapping drill to drill a 1 ½" BSP hole on the surface of the tank.
- Place the foam gasket over the hole followed by the mounting adaptor.
- Tighten on to tank with 2 stainless steel self-tapping, counter sunk screws, supplied. Do not over tighten!
- Screw the sensor into the adaptor. Ensure that the sensor is vertical on the tank and screwed correctly into the base and that the threads have not crossed, to give a secure seal



Appendix 2: Waveguide

Note: The default sensor configuration is non-waveguide mode and the measurements will be inaccurate unless a waveguide configuration mode is used.

- Source a suitable pipe to act as the waveguide. This pipe should conform the dimensions in the figure below in order to fit the sensor. The recommended pipe material is PVC (domestic waste pipe is often used). Other materials are possible but should be checked for chemical resistance to fuel oil.
- Cross-section of waveguide pipe assembly:

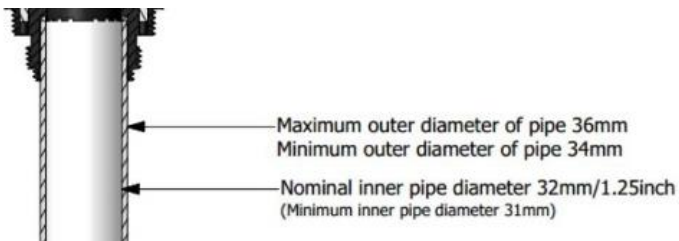

- The pipe should be cleanly cut to length. The length required should be measured from the top of the tank (where the sensor is to be mounted) to that of the fuel outlet point (as shown).



Note: The bottom of the pipe should be a minimum of 5cm from the base (floor) of the tank to prevent it from touching in the case of tank dimensional changes due to temperature etc.

- The waveguide pipe should be securely attached via the two grub screws and hand tightened with an M1.5 Allen key (Note: over-tightening the grub screws can damage the plastic). Care should be taken to keep the sensor and pipe vertically aligned and supported, while fitting during the installation.

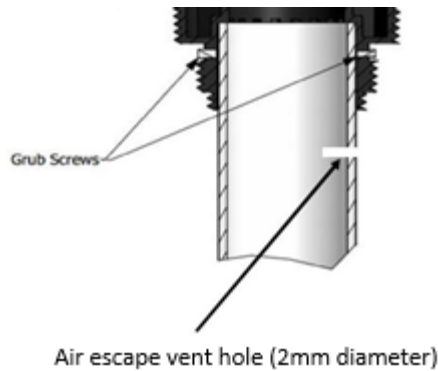

Note: Depending on the weight, length and surface finish of the pipe, it may be necessary to glue it into position. In this case a hole should be drilled near the top of the waveguide pipe, just below the adaptor, to ensure that any trapped air can exit.

- Insert the correctly sized rubber seal ring, as required for the tank opening (supplied), and position it on the face of the adaptor that is screwed onto the top of the tank.



- Insert the whole assembly carefully into the tank, taking care not to loosen the pipe, and fit into position. Hand tighten the assembly until the rubber seal locks into position.

For more information on the Tekelek Ultrasonic GSM 2G sensor please visit our website www.tekelek.ie where a link to our YouTube page can also be found.